

COLLECTING

The study of mammals frequently requires that they be captured and/or prepared as specimens. Many detailed investigations can be carried out only when the mammal is in captivity or has been prepared as a museum specimen. Taxonomists require specimens to document the presence of species in particular localities, to assess geographic and other types of variation, and to prepare reviews and keys on various groups of mammals. Scientists interested in life history studies of mammals collect specimens to assess reproductive patterns or food habits. Population biologists capture mammals alive, mark them for permanent identification, and later try to recapture the marked animals, to obtain data on population sizes and population structures. All behavioral and many cytological studies require live mammals for field or laboratory investigations. These are only a few of the many types of research that require the collection and/or capture of mammals. Additional information on the use of mammals in research and educational settings can be found in publications of the American Society of Mammalogists (*ad hoc* Committee for Acceptable Field Methods in Mammalogy 1987; *ad hoc* Committee for Animal Care Guidelines 1985; Animal Care and Use Committee 1998) and the Association for the Study of Animal Behavior (Association for the Study of Animal Behavior 1996).

HEALTH AND SAFETY

Some large mammals (e.g., proboscideans, artiodactyls, perissodactyls, and others) pose threats to researchers attempting to capture, handle, and mark these animals.

For such mammals, specialized handling facilities or drug immobilization from a distance may be required to minimize danger to the investigator. The researcher should always be aware of the behavior and habits of the animals under study to minimize risk and to lessen the chance for potentially dangerous encounters.

Some mammals may harbor potentially dangerous pathogens that can be life-threatening (Kunz and Gurri-Glass 1996). The site where the work is to be conducted may also present risk to the researcher due to the prevalence of particular human diseases or toxins in the area of study. The investigator should always consult with a physician prior to undertaking any field work in a foreign country or with particular groups of animals that may pose a health risk (Animal Care and Use Committee, 1998; Kunz and Gurri-Glass 1996). Investigators planning to work in tropical areas of the world should consult with appropriate health agencies (e.g., in the United States, the Centers for Disease Control; and the Public Health Service), medical professionals, and papers such as Kunz and Gurri-Glass (1996) for specific guidelines. In the sections that follow, we have provided information on some of the most serious diseases that may be transmitted from mammals to humans or from habitats frequented by mammals.

Rabies

Rabies is an almost invariably fatal disease caused by *Lissavirus* and transmitted most often in the saliva of an infected animal to a wound caused by the infected animal or to broken skin. In humans, the incubation period is typically two to 12 weeks with a range of 10 days to 15

months (Kunz and Gurri-Glass 1996). The World Health Organization (WHO) and the U.S. Centers for Disease Control recommend that all individuals who have regular contact with bats or other high risk mammals (e.g., carnivores) should be immunized against rabies (Kunz and Gurri-Glass 1996). Persons bitten by animals should wash the wound thoroughly with soap and water followed by a disinfectant (e.g., 70% alcohol). Postexposure vaccination against rabies following such a bite is always advisable (Kunz and Gurri-Glass 1996).

Hantavirus

At least two variants of hantavirus are known to infect humans, and certain species of rodents are the primary vectors (Mills et al. 1995). In the United States, a particularly virulent form of hantavirus that causes hantavirus pulmonary syndrome (HPS) was recognized in 1993. HPS symptoms appear within 45 days after exposure and the initial symptoms including fever, headache, fatigue, vomiting, shortness of breath, and a dry cough; later symptoms include rapid heartbeat, breathing difficulties, and abrupt respiratory failure (Kunz and Gurri-Glass 1996).

The principal vector of this disease in the United States is the deer mouse, *Peromyscus maniculatus*, although other species of *Peromyscus* have been implicated. Mills et al. (1995) provided specific precautions for working with rodents that may be infected, along with recommendations for decontamination of work surfaces, instruments, cages, and traps. Workers should avoid feces and urine of infected animals unless appropriate protective gear is utilized.

Histoplasmosis

Histoplasmosis is a disease of mammals, caused by the soil fungus *Histoplasma capsulatum*, and is often associated with high concentrations of animal feces such as guano deposits in caves (Animal Care and Use Committee 1998; Kunz and Gurri-Glass 1996). Workers visiting caves where this organism is potentially present should wear a respirator equipped with filters that can exclude particles as small as 2 microns (μm) or use a self-contained air supply (Kunz and Gurri-Glass 1996).

Lyme Disease

Lyme disease is caused by the bacterium *Borrelia burgdorferi*, which is carried by ticks in the *Ixodes ricinus* complex (Kunz and Gurri-Glass 1996). This disease was first noticed in the United States in 1975 near the town of Lyme, Connecticut, but is now known to occur in virtually every part of the United States. In the northeastern United States, the principal reservoirs of the disease are the deer tick (*Ixodes dammini*) and the white-footed mouse (*Peromyscus leucopus*), but humans get the

disease by receiving a bite from the tick (Kunz and Gurri-Glass 1996). Symptoms of the illness include a red, ring-shaped rash that appears about two to five days after the tick bite; weakness, dizziness, muscle aches, sore throat, and swollen lymph glands are also noted (Kunz and Gurri-Glass 1996). Prior to field work, use tick repellents (particularly those that contain DEET) and, following field work, search the body for any crawling or attached ticks (Kunz and Gurri-Glass 1996).

Other Diseases

Refer to Kunz and Gurri-Glass (1996) and Animal Care and Use Committee (1998) for information on *tularemia* and *plague*.

COLLECTING, CONSERVATION, AND THE LAW

Ethics and the Law

Investigators should collect only the number of specimens needed for a particular project and in accordance with guidelines of professional societies (*ad hoc* Committee for Acceptable Field Methods in Mammalogy 1987; Animal Care and Use Committee 1998). Further information on the ethics of collecting and care of mammals can be found in Rudran and Kunz (1996) and Friend et al. (1996).

In recent years, increasing concern on the part of many individuals for the conservation of flora and fauna and for the protection of threatened and endangered species prompted the passage of many federal and state laws. These and earlier laws regulate the salvage, capture, possession, transport, and sale of certain species of animals and affect, in many instances, the manner in which scientific and educational activities involving these animals can be conducted.

Federal and International Regulations Pertaining to Collecting

In the United States, the Endangered Species Act (Code Federal Register, CFR 50.17) and the Marine Mammal Protection Acts (CFR 50.18, 50.216) provide important protections through listing and regulation of endangered species. In addition, the Lacey Act, in part, regulates the importation and exportation of nonendangered species and injurious wildlife (CFR 50.10, 50.13, 50.14, 50.16).

The Convention on International Trade in Endangered Species (CITES) of Wild Fauna and Flora, TIAS 8249, to which the United States is one of 146 member nations, bans commercial international trade of listed endangered species by member nations. The Convention

defined three categories of species (listed in Appendices I, II, and III, as listed below):

- Appendix I: All species or other taxa threatened with extinction.
- Appendix II: All species or other taxa not presently threatened with extinction, but those in which trade must be restricted to ensure their survival.
- Appendix III: All species or other taxa identified by a particular country as subject to conservation regulations within that country and requiring the cooperation of other parties to the convention.

For importation (or exportation) of animals and animal products into (or out of) the United States, the provisions of CITES, the Endangered Species Act, the Marine Mammal Protection Acts, and applicable regulations of the Department of Agriculture (e.g., those related to animal care and use) must be adhered to. Refer to Genoways and Choate (1976), Berger and Phillips (1977), and McDiarmid et al. (1996), and recent updates of the pertinent sections of the U.S. Federal Code, for specific guidelines and the provisions of these regulations.

Federal Laws and Regulations Pertaining to Care, Handling, and Transport of Mammals

Mammals maintained in captivity for more than a few days are generally subject to the provisions of the Animal Welfare Act of 1985. This act, enforced by the U.S. Department of Agriculture, is designed to ensure the humane handling, care, treatment, and transportation of regulated animals used for research or exhibition, sold as pets, or transported in commerce (Friend et al. 1996). Most institutions that have animal-holding facilities are generally subject to provisions of this act, as are the recipients of many federal grants from agencies such as the National Science Foundation and the National Institutes of Health.

State Regulations

The complexity, number, and lack of uniformity in state laws regulating scientific collecting have prompted some scientists to urge the adoption of uniform regulations among states for this activity (see McGaugh and Genoways 1976). Until realistic and uniform regulations exist for all states, it is necessary for scientists and students to follow the appropriate nonuniform state and local regulations pertaining to specimen acquisition. Refer to McGaugh and Genoways (1976) and to Berger and Neuner (1981) for a summary of state laws regarding scientific collecting permits and for addresses where copies of the latest regulations for each state can be

obtained. This is a rapidly changing area, and you are advised to consult with the appropriate state and wildlife agency for the latest laws and regulations.

CONSERVATION

Populations of many species (e.g., certain cave bats) not considered threatened or endangered at present can nonetheless be permanently harmed by indiscriminate collecting. All collecting should be carried out for a valid purpose (*ad hoc* Committee for Acceptable Field Methods in Mammalogy 1987; Animal Care and Use Committee 1998), and the purpose should dictate the amount and type of collecting. For instance, a project to document the occurrence or distribution of a species in a given area would normally require collecting only a few individuals at a variety of locations, whereas a study of individual variation within a population might require larger numbers from fewer locations.

Many bat colonies are particularly susceptible to disturbance. The slightest provocation will cause many species to desert roost sites, and such provocation can be extremely harmful if it disturbs a nursery colony or a hibernaculum. Whenever possible, get an expert opinion before disturbing bat colonies, and when collecting in them, create as little disturbance as possible.

LOCATING A COLLECTING AREA

Obtain permission from landowners or lease holders before collecting in an area. Failure to do so may subject you to arrest for trespassing. Often, the landowners will be able to direct you to favorable collecting sites when you observe this courtesy. A large percentage of the federal land in the United States is available for collection, with permission, but state game laws and applicable federal laws must be followed (see McGaugh and Genoways 1976).

After you reach the collecting area, make a visual survey to determine where to concentrate your efforts. Some species may be restricted to particular types of habitat, but others may occupy several habitats. After the appropriate habitat area is located, look for "sign" before placing traps (see Chapter 28).

After you finish collecting in an area, always remove all trap markers, wire, plastic, cloth, paper, and any other debris from the site.

RECORDS

Keep a careful record of all collecting activities. It is very important to know when, where, and how the specimens were collected. Always keep the data closely associated with live animals housed in cages and with dead animals stored in a freezer. Refer to Chapter 29 for record-keeping techniques.

METHODS OF TRAPPING MAMMALS

Kill Traps

The traps listed below are valuable for most forms of collecting when it is not necessary to acquire live animals. They are frequently more effective and less expensive than live traps.

Snap Traps

Snap traps are by far the most important trap type for general collecting. Snap traps come in three basic sizes. The largest, the **rat trap** (Fig. 30.1A), and the smallest, the **mousetrap**, are generally available and familiar to most people. The rat trap is used to catch rats, *Rattus*; woodrats, *Neotoma*; chipmunks, *Tamias*; the smaller ground squirrels, *Spermophilus*; and similarly sized mammals. Smaller mammals, (e.g., most *Peromyscus*, *Microtus*, and *Blarina*) can be taken in rattraps, but the strength of the springs on these traps may cause damage to the specimens. Because of the small distance between the sprung wire bail and the bait pan of mousetraps, the skulls of mammals collected with them are usually crushed. Because the skull is an important part of any museum specimen, mousetraps are very seldom used for scientific collecting. **The Museum Special** (made by Woodstream Corp., Lititz, Pennsylvania) is especially designed for collecting small mammals for scientific purposes (Fig. 30.1B). It is larger than a mousetrap but less powerful than a rattrap. Its design greatly reduces the frequency of skull damage. West (1985) reported that the new design of the Museum Special trap, compared with

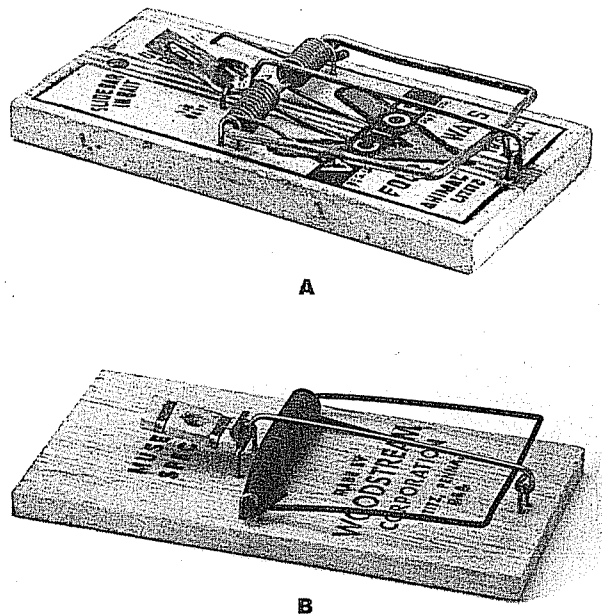

Figure 30.1 Examples of snap traps. (A) Rat trap; (B) Museum Special.
(R. E. Martin)

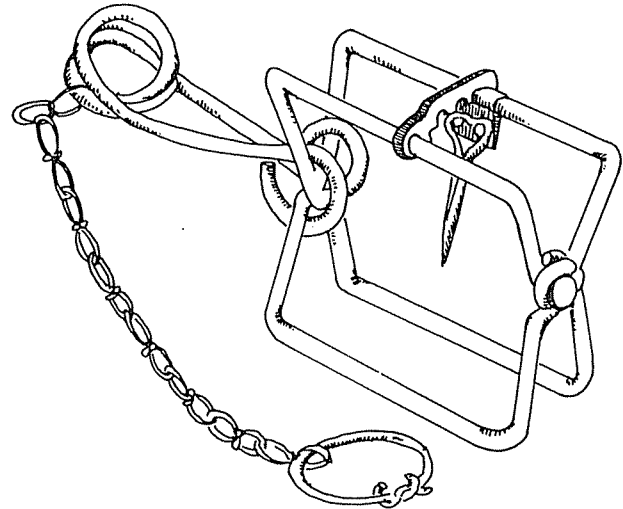

Figure 30.2 Conibear trap, shown set.

(Stains, H.J. 1962. Game biology and game management; a laboratory manual. Burgess Publishing Co., Minneapolis. 143 pp., fig 7e. With permission of the publisher.)

the old style of this trap, was less adept at catching chipmunk-sized mammals but better able to secure some smaller species of mammals such as shrews.

To set any of the snap traps, place a small quantity of bait on the pan and adjust the trigger mechanism so that it will be set off with a light touch. Because woodrats are adept at collecting these traps and adding them to their den debris, it is wise to wire the traps to a rock or branch when trapping near woodrat dens.

Steel Traps

Steel leghold traps are used primarily by fur trappers and infrequently for scientific collecting (*subject to state regulations*). These traps usually catch mammals by one leg and generally do not kill. However, they are included under the "kill trap" classification because they usually severely damage the animal and necessitate killing it. These traps cannot be considered humane and should not be used unless they are padded and checked frequently (Animal Care and Use Committee 1998).

If steel leghold traps are used, set the traps under water so that the caught animal quickly drowns. The **Conibear Trap** (Fig. 30.2) is a humane alternative to the steel leghold trap. This trap comes in a variety of sizes and often can be substituted for the smaller-sized leg traps. The Conibear trap generally kills animals very quickly.

Gopher Traps

Several traps designed specifically to catch gophers are manufactured in the United States. A style that is widely available and easily set is shown in Figure 30.3. The traps are set in underground runways, singly (Fig. 30.4A) or in pairs (Fig. 30.4B), and are tied to a stake to prevent them from being dragged deep into the burrow system by the

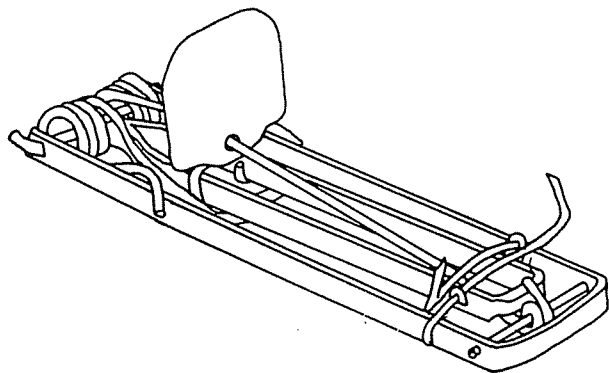

Figure 30.3 Macabee-type gopher trap, shown set. Suitable for capturing all but the largest pocket gophers.
(R. E. Martin)

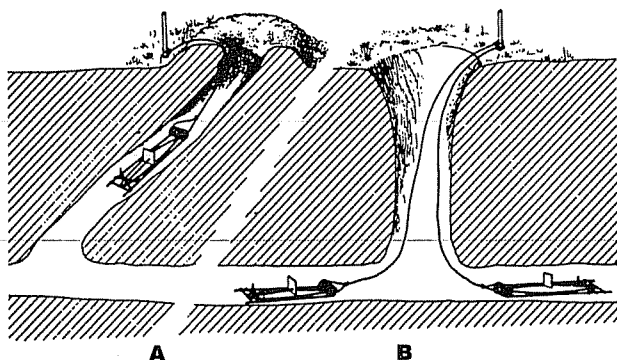

Figure 30.4 Single- and dual-trap sets for pocket gophers. (A) Single set in lateral tunnel; (B) dual set, back to back, in main tunnel.
(Crouch 1933:17)

captured animal. The tunnel is left open so that the gopher will push dirt over the trap and in so doing set off the trigger mechanism. These traps must be checked every 15 to 30 minutes to get maximum benefit and minimize discomfort to captured animals.

Mole Traps

The **harpoon mole trap** (Fig. 30.5) is the most commonly used mole trap in the United States. It is set on the surface. The mole tunnel is pressed down and the trap pushed into the ground so that it straddles the collapsed tunnel. The trigger mechanism is cocked, and the height of the trap is adjusted so that the mechanism will be raised and thus set off by the mole as it travels just under the surface of the ground.

Live Traps

Live traps offer several advantages over kill devices. Animals that are needed alive can be taken back to the laboratory for further investigation or studied or marked at the trap site and then released. In areas where endangered or threatened species may occur, the use of live

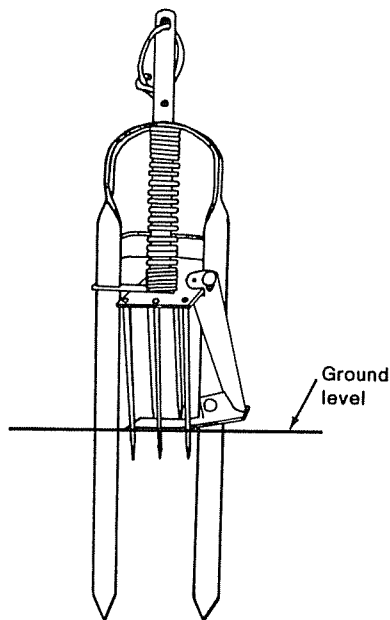

Figure 30.5 Harpoon mole trap, shown set.
(R. E. Martin)

traps will minimize the chance of harming these forms and may be required by federal or state regulations governing the issuance of a permit to the investigator.

Arrange the traps so that the animals will be protected from extremes of cold and heat, and check them frequently for any captures. In cold weather, provide cotton (but *not* polyester because animals may be entangled and injured in this material) or other suitable insulating material.

Commercial Traps

Several manufacturers produce and market live traps in a range of sizes to capture everything from mice to coyotes. Some firms make types large enough to capture small deer. In the United States, welded wire traps (Fig. 30.6) are made by several companies including Allcock Manufacturing Co. (Havahart® brand traps) and Tomahawk Live Trap Co. These traps (made in collapsible or noncollapsible varieties) have either one or two doors and are activated by a small bait pan in the center of the

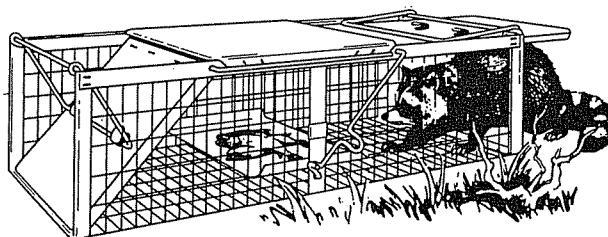

Figure 30.6 Havahart® trap, one of several varieties of welded wire live traps.
(Allcock Manufacturing Company)

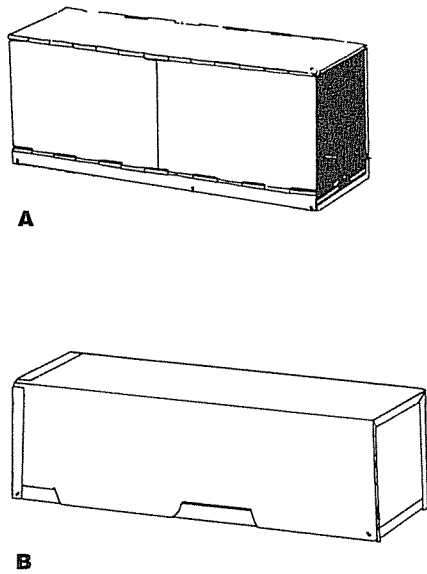

Figure 30.7 Folding (A), shown set, and nonfolding (B) with door closed, models of Sherman live traps. (G. A. Moore)

trap. The **Sherman trap** (H. B. Sherman Traps) is made of galvanized sheet iron or aluminum in folding (Fig. 30.7A) or nonfolding (Fig. 30.7B) models. The **Longworth trap** (Longworth Scientific Instrument Co., Ltd.) is made of aluminum and is composed of two sections: a trap and trigger mechanism, and a detachable nest box. This added feature provides greater protection of the captured animal from the elements and makes for easier handling of the live mammal in the field. Several investigators have reported potential bias with the use of this trap. Grant (1970) reported that lighter-weight animals are not caught as readily in Longworth traps as the heavier animals. Boonstra and Rodd (1982) found that some heavier species of voles (e.g., *Microtus pennsylvanicus*) sometimes sprung the traps without being caught; they suggested replacing the standard treadle in the Longworth trap with one that was about 1 inch (2.54 cm) longer.

Homemade Traps

Many types of live traps can be made relatively easily and inexpensively. If a particular trap design does not suit your needs, the plans may be modified so that the trap will capture the species that are desired. The **Gen trap** (Fig. 30.8) was originally designed by Shemanchuk and

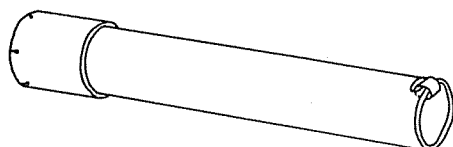

Figure 30.8 Gen trap, with removable rear closure. (R. E. Martin)

Bergen (1968) for use in ground squirrel burrows. However, this trap is adaptable to other species by modifying the diameter of the pipe and the method of setting. The Gen trap is constructed of economical materials and is easily made and transported. The **Fitch trap** is dependable and widely used for many species of rodents. This trap is constructed of hardware cloth, galvanized metal, wire, and a metal can (see Fitch 1950, for details on original design, and Rose 1973, for modified version). Pocket gophers, Geomyidae, are somewhat difficult to live-trap, but Baker and Williams (1972) reported good results with their design (Fig. 30.9). Earlier, Howard (1952) designed a live trap for pocket gophers that was the standard for many years.

According to Moore (1940), moles can be captured alive using modified kill traps (Fig. 30.10). Arboreal mammals can be captured in a variety of homemade traps including one designed to capture sugar gliders, *Petaurus breviceps* (Mawbey 1989).

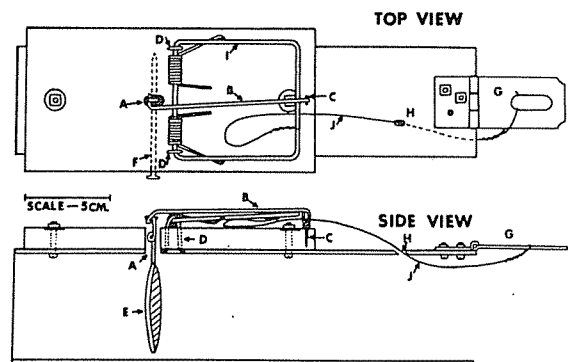

Figure 30.9 Live trap for pocket gophers. (Baker and Williams 1972)

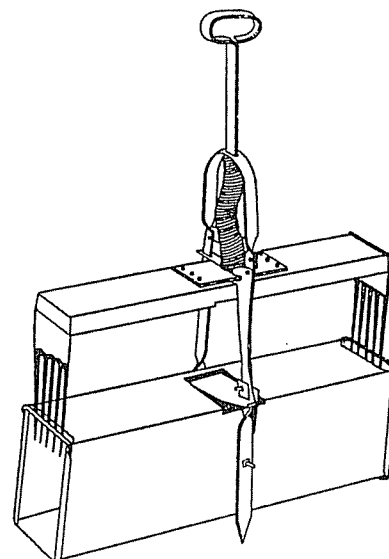

Figure 30.10 Live trap for moles. (Moore 1940:224)

Additional designs for live traps can be found in Burt (1927), Garlough et al. (1942), Gilmore (1943), Howard (1953), LoBue and Darnell (1958), Taber and Cowan (1969), and Jones et al. (1996).

Pitfalls

Tall cans or jars, placed in the ground with their rims even with the surface, are useful in catching small mammals, particularly shrews. Provide an adequate quantity of food in the container and check frequently for captures. Baffles (drift fences) pressed vertically into the ground increase the effectiveness of pitfalls by guiding mammals toward them. Williams and Braun (1983) compared the effectiveness of pitfall and conventional traps for securing small mammals.

Runways, Corrals, and Box Traps

Larger mammals (even rabbits and hares) may be herded along runways into corrals. Care must be taken to avoid injuring the animals during the chase because most will be released. Most states restrict this activity, and usually only qualified professional biologists or game wardens engaged in management or research programs may utilize this technique. Check with game officials before attempting this procedure, and secure the necessary permits. Foreyt and Glazener (1979) provided plans for a box trap suitable for capture of deer or feral hogs.

Special-Purpose Traps

Beavers may be taken in either Bailey or Hancock traps, and muskrats in Snead traps (see Couch 1942; Taber and Cowan 1969). Because these animals are furbearers, they may generally be captured during furbearer season only or under the provisions of a scientific collecting permit.

METHODS OF TRAP PLACEMENT

Snap traps and most types of commercial and homemade live traps can be distributed by any of the following three methods. The other types of traps are almost always placed according to the sign method. Additional information on methods for placing traps can be found in Jones et al. (1996).

Sign Method

With the **sign method** of trap placement, appropriate fresh mammal sign is located, and a trap is positioned to catch the animal. Although this method generally produces the best results, it is more time-consuming than the other methods that follow. To facilitate relocating traps placed in this manner, either each trap must be marked with a conspicuous trap marker or else detailed notes must be kept. The sign method could result in a biased sample of the species present because those small mammals that leave little or no conspicuous sign are less likely to be collected.

Paceline Method

The **paceline method** places traps at regular intervals. One technique is to select a starting point and mark it with a strip of conspicuously colored cloth or plastic surveyor's tape. Sight toward a distant landmark and place traps at regular intervals as you walk toward that point. Trap markers are usually placed at the beginning and end of each line. If the line is particularly long or if the habitat has dense ground cover, it is prudent to also mark every fifth or tenth trap location. The paceline method generally allows for the placement of a maximum number of traps in a minimum amount of time and is also free of the bias mentioned earlier. However, it will usually result in a lower percentage of captures than the sign method.

Grid Method

A trap grid is a series of parallel trap lines. Grid trapping is most frequently utilized in life history studies where mammals are marked and recaptured (see Chapter 36). The size of the grid is dependent on the species to be captured and the type of study. In small rodent studies, for example, the grids are often arranged in 12 rows and 12 columns (144 traps total), with each trap station 15 to 20 meters from an adjacent station. The traps are usually placed without regard to sign.

TIMING OF TRAPPING ACTIVITY

Because most small mammals are crepuscular or nocturnal, traps are usually set just before dusk and checked or collected in early morning. Ants and other small invertebrates will eat the bait if the traps are set too early in the day, and they can ruin trapped specimens if the traps are not checked soon after dawn. It is frequently productive to check traps during the night, remove trapped mammals, and reset the traps. Fleas will leave a specimen as soon as the body cools, so frequent checks of kill traps are necessary if you are interested in collecting these ectoparasites.

To catch diurnal mammals such as ground squirrels, traps can be set any time during the day. But they should be checked at frequent intervals, particularly in hot weather, to minimize decomposition in killed animals or heat stress or death in individuals that are live-trapped.

Weather conditions will frequently influence trapping success. A heavy rain may wash the bait off of traps or may set them off. A heavy snowfall can bury traps and make them very difficult to relocate. The activity patterns of some mammals may be influenced by the weather or by the phase of the moon. Kangaroo rats, *Dipodomys*, for example, are more active and therefore more readily collected when there is no moonlight.

CALCULATING TRAPPING SUCCESS

Trapping success is given as the percentage of the traps that produce specimens. Thus, if 100 traps were set and 10 mammals were collected, the trapping success would be 10%. The number of traps used multiplied by the number of nights they were in position is referred to as the number of **trap nights**. Thus, 100 traps set for one night equals 100 trap nights, 20 traps set for five nights equals 100 trap nights, and 20, then 40, then 30, and then 10 traps set on four successive nights still equals 100 trap nights. Trapping success is also frequently given as a percentage of trap nights.

The trapping success to be expected varies considerably with the habitat, type of trap, trapping method, population density, and many other variables. In the United States, a paceline of snap traps in moderately good habitat will usually produce about 10% success. In the American tropics, trapping success is generally much lower.

See Chapter 36 for additional references and for techniques that can be used to determine relative abundance or densities.

BAITS AND SCENTS

Baits

Bait may be preferred seasonal food or a substance entirely new to the animal. For rodents, the most commonly used bait in temperate North America is a mixture of peanut butter and oatmeal (mixed bird seed is sometimes added). To catch insectivores, it is helpful to add a small quantity of meat or fish to the mixture. Most carnivores will be attracted by canned dog food or fish products, whereas rabbits and similar herbivores require apples, carrots, or lettuce. Dead animals may also be used to attract mammals to traps.

In many areas, ants can kill mammals in live traps, remove bait, or otherwise be a big problem. A change of bait may be effective in minimizing its loss to insects. Getz and Prather (1975) mixed shredded cotton into heated peanut butter to retard the removal of the bait by insects.

Scents

Scent baits are very effective with many mammal species because the odor may arouse sexual interest, antagonism, or curiosity. Scents may be superior to food baits for mammals that communicate by odor. In general, valerian (prepared from *Valeriana* sp.) is attractive to carnivores of the family Canidae, and catnip (*Nepeta* sp.) is attractive to the black bear, *Ursus americanus*. Beaver castor or castoreum (prepared from musk sacs of both sexes of *Castor*) elicits a positive response from beavers. Refer to Taber and Cowan (1969) for instructions on how to prepare and use various scents.

MINIMIZING DAMAGE TO TRAPPED MAMMALS

At times, larger mammals (particularly carnivores) may disturb or injure smaller mammals caught in live traps. Getz and Batzli (1974) designed a cage that is placed over a live trap to minimize this possibility.

In areas where ants may cause damage to specimens (e.g., tropics, deserts), traps must be checked frequently (including nighttime hours) to remove captured mammals. Frequent checking of kill traps may also minimize damage resulting from the activities of shrews, carnivorous rodents (e.g., *Onychomys*), and small carnivores.

Traps must be checked frequently during warm weather. Mammals held in live traps may overheat and die, and specimens in kill traps may decompose quickly under such conditions.

ADJUSTING TRAPPING METHODS FOR REGIONAL AND CLIMATIC DIFFERENCES

Most of the advice contained in this chapter applies to North American temperate conditions. You may have opportunities to collect in other countries and other climatic areas. Often, you can learn important techniques by talking with persons experienced in trapping in these areas. Papers in the *Journal of Mammalogy* and similar journals are also helpful, as are the introductory sections of many regional faunal works.

OTHER METHODS OF CAPTURING OR COLLECTING MAMMALS

Hunting

Larger species of mammals are generally collected using a rifle or shotgun. Small species, if not trapped or collected by some other means, can be collected using a shotgun. Specimens collected for scientific purposes must be killed in a manner that causes the least damage to the specimen or to the body parts required for study. Remember that firearms impose an obligation upon the user to handle them safely and in compliance with local and state laws.

Shotguns of 12, 16, 20, or .410 gauge are generally used to collect smaller mammals. Very small species are best collected with .22 caliber rifles or pistols (preferably smoothbore) loaded with bird shot, or a .410 shotgun with half-loads of No. 12 shot. Rifles loaded with ball ammunition are generally used on the larger species. A combination rifle-shotgun, e.g., a ".22-.410 overunder" is a very versatile firearm for collecting. A .22 cartridge will handle most species up to the size of a raccoon or badger. Larger calibers are necessary for larger carnivores and large herbivores. If you anticipate collecting some of the

larger mammals, it would be well to seek the advice of a person experienced in firearms and hunting and comply with all laws and regulations.

Drug Immobilization

Large mammals that must be captured alive are usually immobilized with drugs to prevent harm to the animal and the captor. The drugs most commonly used are nicotine salicylate and succinylcholine chloride. To achieve proper dosages, it is necessary to have a fairly accurate method of estimating weights of the target animals. Taber and Cowan (1969) listed approximate dosages for a list of selected mammals. Harthoorn (1965, 1975) provided a comprehensive treatment of this specialized field, and Twigg (1975b:89–91) gave a particularly succinct account.

The drugs are administered by means of specially designed syringes attached to arrows or firearm projectiles. The Cap-chur gun is a commercial form of such a device. In most states, drug immobilization can be conducted only by qualified scientists, game management personnel, or zoological garden staffs. Consult local game officials before attempting this procedure because the procedure is regulated, as are the drugs used in the delivery devices.

Corral Traps and Nets

Taber and Cowan (1969:286–90) described and illustrated several types of herd and drift traps for the capture of large mammals. A radio-controlled drop net was used by Ramsey (1968) to capture white-tailed deer (*Odocoileus virginianus*) and axis deer (*Axis axis*). All of these methods are subject to state regulations and are generally not used by personnel not employed by state or federal game agencies.

Den Investigation

Woodrats, *Neotoma*, some species of kangaroo rats, *Dipodomys*, and several other species can frequently be dug out of their dens and then captured by hand, with a net, or shot with firearms. In most states, it is illegal to collect game and furbearing species and many other species in this manner. Consult applicable regulations and game officials before using this procedure.

Hand Capture

Many nocturnal mammals, particularly certain rodents, can be captured by hand or with a net. A light is shone in the animal's eyes, causing the animal to remain motionless while approached and captured. You will feel safer wearing gloves, but many species make no attempt to bite. Hand capture can be conducted by walking through fields with a lantern or by driving slowly along infrequently traveled roads. Spot-lighting for game species is illegal in most states. Consult state and federal wildlife laws before attempting this procedure.

Bat Collecting

Prior to collecting bats, consult papers such as Kunz et al. (1996) to learn about the ethics involved and potential harm that might be done to populations. In general, bats may be collected by netting, with the Tuttle trap, with harp traps, or by hand, all of which allow you to ascertain the species involved prior to removal from the population.

Bats may be caught in **mistnets** (Fig. 30.11), bat traps (Fig. 30.12), or by hand. The nets are strung over water holes (especially in desert regions), across streams, or across trails or narrow clearings in timbered areas. Bats can also be collected by hand from bridge expansion joints, old mine tunnels, caves, attics, belfries, or other sites (see Greenhall and Paradiso 1968). Francis (1989) compared the success of mistnets with two different styles of harp traps for securing bats.

Be especially careful about collecting bats from suspected breeding or nursery colonies. In the United States, the gray bat, *Myotis grisescens*, the Indiana bat, *Myotis sodalis*, and several others are endangered species and must not be disturbed or captured without permits from the U.S. Fish and Wildlife Service and appropriate state agencies. Determine the specific identity of any bats in a newly found colony before collecting any. Some nursery colonies are extremely sensitive to disturbance (e.g., movement, light, noise) and may abandon the location, with adverse results to the popula-

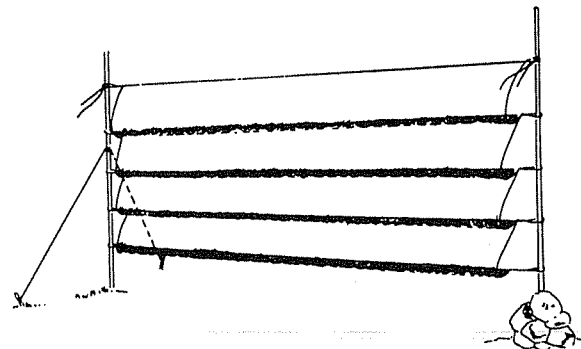

Figure 30.11 Mistnet used in capturing bats. (Greenhall and Paradiso 1968)

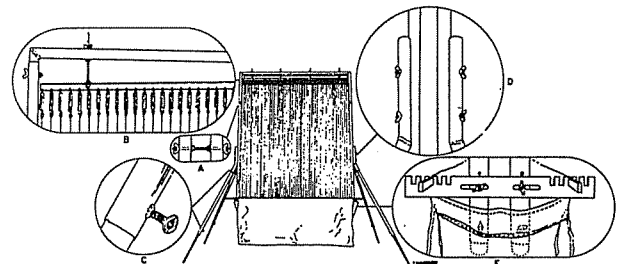

Figure 30.12 Double-frame Tuttle trap showing details of construction. (Tuttle 1974:476)

tion. Disturbing bats during hibernation can result in stored energy loss, which may keep them from surviving the winter.

Several specialized techniques have been devised for capturing bats in conjunction with population, movement, and other life history studies. Many of these techniques were discussed and illustrated by Tuttle (1974), Greenhall and Paradiso (1968), Barbour and Davis (1969), Constantine (1958, 1969), and Kunz (1988). Kunz et al. (1996) and Kunz (1996) provided detailed information, with excellent illustrations, on how to capture, handle, and mark bats for study. Also, consult issues of *Bat Research News* (1960 to present).

Salvage

Many good records result from collecting mammals that are found dead on the road (abbreviated **DOR**). The specimen may be damaged, and often the skull is crushed, (making it less useful to neontologists but more useful to paleontologists), but most tears can be sewn up to make a suitable preparation. Often the specimen will be bloated and have a foul odor, but a good preparation can still be made if the hair has not started to **slip** (that is, if large patches cannot be easily pulled free from the underlying dermis).

Raptor pellets (both hawk and owl) frequently yield valuable mammal specimens. These are a particularly good source of shrews, which are not often caught in traps. Only skeletal material and matted hair will remain, but specific identity of the prey species is usually possible.

Occasionally, weathered skulls, leg bones, vertebrae, and other skeletal elements are found in the field. Such remains of animals that died of natural causes or predation can be identified and often provide useful locality records.

Frequently, it is possible to obtain hides, skulls, and/or other material from animals killed by hunters and trappers. With appropriate state permits, such specimens can be sources of important records.

Whenever possible, salvage should be used to increase the size of series, document distribution, record variation, provide internal organs for analysis, etc. Salvage is the one type of collecting that does not require that the scientist disturb a population.

Permits must be obtained from federal and state agencies to salvage specimens of endangered species, marine mammals, or any specimen found in a national monument or a national park in the United States. Otherwise, you may be subject to arrest and stiff fines for possession of these animals (Berger and Phillips 1977; McGaugh and Genoways 1976:80–81). Collecting of game animals and forbearers, and many nongame species, is generally subject to state regulations, and you must have the necessary license or permit to secure or handle these mammals.

MARKING MAMMALS

It is frequently necessary to mark individual mammals for studies of population density, home range, homing, migration, or other behavior. Detailed information on how to mark mammals is found in Kunz (1996) and Rudran (1996).

Tagging

Tagging involves the attachment of a metal or plastic tag to an animal. The tags are frequently numbered for individual recognition and may be attached to the ear, in blubber (whales), or around the neck or leg. Small rodents are frequently marked with fingerling tags attached to the ear. Microchiropteran bats are tagged (banded) with lip-end bands secured loosely around the distal portion of the forearm (Kunz 1996). Greenhall and Paradiso (1968) and Bonaccorso et al. (1976) described banding techniques for use with bats and improvements in procedures. **PIT transponders** have been used in recent years to provide permanent individual identification for animals (Fagerstone and Johns 1987). A cylinder containing a transmitter with a unique frequency is injected into the dermis of the mammal, and the identification is read with a special receiver. Twigg (1975c), Kunz (1996), and Rudran (1996) provided useful information on how to mark mammals.

Collar tags are frequently marked with reflective tape or plastic streamers so that individuals of large species (usually carnivores or ungulates) can be identified at a distance. Taber and Cowan (1969) and Knowlton et al. (1964) discussed several of these methods in detail. Buchler (1976) designed a chemiluminescent tag for tracking bats and other small nocturnal mammals; Heidt et al. (1967) utilized an implanted magnet to track the movements of voles (*Microtus*) in an enclosure.

Coloring and Freeze Marking

Dyes are useful in marking mammals for behavioral investigations. The black dye, Nyazol D, can be applied to any species that has pale pelage. Several individuals can be marked with the same color by applying the dye to different regions of the body. Refer to New (1958), Haresign (1960), Taber and Cowan (1969), and Taylor and Quay (1973) for additional dyes and methods.

A pressurized refrigerant (dichlorodifluoromethane, CCl_2F_2) was used by Lazarus and Rowe (1975) to apply permanent markings (by changing the natural pigmentation pattern of the hair) on individuals of several species of rodents. More recent techniques use a mixture of dry ice and alcohol to cool the branding iron for freeze marking (Rice and Kalk 1991). In contrast, marks made by pigment dyes such as Nyazol D last only until the dyed hair is shed in a molt.

Radio-Location Telemetry

Collars with radio transmitters and battery packs (or solar cells) can be attached to the necks or backs of animals to provide information on movements, activity, and physiological states (e.g., resting, moving, etc.). Individuals can be distinguished by differences in frequencies or pulse rates (clicks). Although the initial cost of the equipment (transmitters, receivers, antennas) is costly, the system offers the advantage of providing many location coordinates at low cost per location, compared with mark-recapture methods (see Chapter 36).

Radio-location telemetry techniques were used by Banks et al. (1975) to study the activity and home range of the brown lemming (*Lemmus sibiricus*) and by Mineau and Madison (1977) to study the movements of white-footed mice (*Peromyscus leucopus*). Brander and Cochran (1969:95–108) provided additional references on the use of radio-location telemetry with a variety of mammals, and a summary of procedures and equipment.

CARE OF COLLECTED MAMMALS

Care of Live Mammals

Live traps should be checked frequently, and any captured mammals should be removed to a suitable holding cage. Mammals held in captivity impose an obligation upon the captor to provide adequate housing, water, and food. Check the animals frequently, especially during the first days after capture, when they are adjusting to captive conditions. In the United States, mammals in captivity are generally subject to the provisions of the Animal Welfare Act, administered by the U.S. Department of Agriculture, which mandates that institutions establish an Animal Care & Use Committee to monitor the treatment of animals in captivity.

Most captive mammals require a constantly available source of water or succulent vegetation. Some mammals need a complex diet for good health, but others will thrive on one that is relatively simple. Most rodents live

well on a diet of commercial rat or mouse chow, although a seed diet is required for some species. Green food such as lettuce should be provided occasionally. Most carnivores can be fed canned and/or dry dog food. Rabbits will thrive on commercial food pellets, supplemented with fresh lettuce or carrots. Consult Crandall (1964) or Lane-Petter et al. (1967) for more information on care of live mammals. Greenhall (1976) provided comprehensive treatment on the care of bats in captivity.

Killing Mammals Humanely (Euthanasia)

It is sometimes necessary to kill a mammal that has been in captivity, is severely wounded, or caught in a live trap. This can be done humanely by a variety of methods. Small mammals can be asphyxiated almost instantaneously by tightly compressing the thoracic cavity until the heartbeat ceases.

Small or large mammals can be killed by placing them in a closed container and introducing a cotton wad saturated with chloroform or ether. (**Caution: these chemicals are highly flammable.**) Carbon monoxide fumes, as from automobile exhaust, can also be piped into the container. (**Danger: Carbon monoxide is an extremely toxic, colorless, and odorless gas that must be used only where there is adequate ventilation.**)

Care of Dead Mammals

Mammals that are to be prepared as museum specimens should be processed quickly to prevent spoilage. Large mammals (e.g., deer) should be eviscerated if skinning will be delayed for several hours. Small mammals must be skinned quickly, be preserved in chemical solutions, or frozen for subsequent processing. If frozen or refrigerated, always enclose a full set of data within the bag that contains the specimen. The freezer bag should be airtight, fastened securely, and have little air in it so as to minimize specimen dehydration and conserve space. Refer to Chapter 31 for detailed specimen preparation techniques.